



MCA 212 Clamp Meter

Instruction Manual



Disclaimer

The manufacturer assumes no responsibility for any consequences resulting from the use or misuse of this product. Product specifications and manual content are subject to change without prior notice.

Part Number : 7603341

GTIN: 6298043998086



Part Number: 7603341





GTIN: 6298043998086

Introduction

Marmonix MCA 212 is battery-powered, true-RMS, auto-ranging digital clamp meters with 6000-count LCD display and backlight.

Safety Information

- To prevent electrical shock, fire, or personal injury, read all safety instructions before use.
- Never exceed the “maximum value” specified.
- Inspect test lead connections and product insulation before measuring above 36V DC or 25V AC.
- Disconnect test leads from the circuit before changing modes.
- Incorrect mode or range selection is hazardous; “OL” will display when input is out of range.
- Safety symbols:

	Hazardous Voltage		Earth
	Double Insulated		Low Battery
	Risk of Danger. Check the User Manual.		



Specifications

(1) Electrical specifications

Electrical Specifications					
Function	Range	Resolution	Accuracy	MAX.Value	Other
DC Voltage	600.0mV	0.1mV	± (0.5%+3)	1000V	
	6.000V	0.001V			
	60.00V	0.01V			
	600.0V	0.1V			
	1000V	1V			
AC Voltage	600.0mV	0.1mV	± (1.0%+3)	750V	40Hz-1kHz
	6.000V	0.001V			
	60.00V	0.01V			
	600.0V	0.1V			
	750V	1V			
DC Current (µA)	600.0µA	0.1µA	± (1.2%+3)	6000µA	
	6000µA	1µA			
DC Current (A)	60.00A	0.01A	± (2.0%+30)	1200A	
	600.0A	0.1A			
	1200A	1A			
AC Current (µA)	600.0µA	0.1µA	± (1.5%+3)	6000µA	
	6000µA	1µA			
AC Current (A)	60.00A	0.01A	± (2.0%+30)	1200A	40Hz-1kHz
	600.0A	0.1A			
	1200A	1A			



Function	Range	Resolution	Accuracy	MAX.Value	Other
Resistance	600.0Ω	0.1Ω	±(0.5%+3)	60MΩ	
	6.000kΩ	0.001kΩ			
	60.00kΩ	0.01kΩ			
	600.0kΩ	0.1kΩ			
	6.000MΩ	0.001MΩ			
	60.00MΩ	0.01MΩ	±(1.5%+3)		
Capacitance	9.999nF	0.001nF	±(5.0%+20)	9.999mF	
	99.99nF	0.01nF	±(2.0%+5)		
	999.9nF	0.1nF			
	9.999μF	0.001μF			
	99.99μF	0.01μF	±(5.0%+5)		
	999.9μF	0.1μF			
	9.999mF	0.001mF			
Frequency	99.99Hz	0.01Hz	±(0.1%+2)	9.999MHz	
	999.9Hz	0.1Hz			
	9.999kHz	0.001kHz			
	99.99kHz	0.01kHz			
	999.9kHz	0.1kHz			
	9.999MHz	0.001MHz			
Duty Cycle	1%~99%	0.1%	±(0.1%+2)		
Diode	√				
Continuity	√				
Temperature	(-20~1000)°C	1°C	±(2.5%+5)	1000°C	
	(-4~1832)°F	1°F		1832°F	

(2) General and mechanical specifications

General Specifications	
Display (LCD)	6000 counts
Ranging	Auto/Manual
Material	ABS
Update Rate	3 times/second
True RMS	√
Data Hold	√
Backlight	√
Low Battery Alert	√
Auto Power Off	√

Mechanical Specifications	
Dimension	240*90*45mm
Weight	288g
Battery Type	9V 6F22 Battery * 1

Environmental Specifications		
Operating	Temperature	0~40°C
	Humidity	<75%
Storage	Temperature	-20~60°C
	Humidity	<80%

Diagram of the product

1. Jaws

2. Jaw Release

3. **Rotary Switch:** selects mode or range (from OFF, clockwise):

- OFF
- AC/DC Voltage
- Frequency
- Resistance/Continuity/Diode/Capacitance
- Temperature
- AC/DC Current (μA)
- AC/DC Current (A)

4. LCD Display

5. Hz/Duty Cycle Button

6. **SELECT:** toggles AC/DC, Resistance/Continuity/ Diode/ Capacitance, or °C/°F.

7. **RANGE:** enters manual range; each press increases range; after highest, returns to lowest; hold 2s to exit manual mode.

8. **COM:** common terminal for all measurements.

9. **VΩHz:** input terminal for voltage, frequency, resistance, continuity, diode, capacitance, temperature, current ≤6000 μA, and duty cycle.

10. **HOLD:** press to freeze reading ("HOLD" displayed); press again to release. Hold >2s to enable backlight; long-press again to disable.

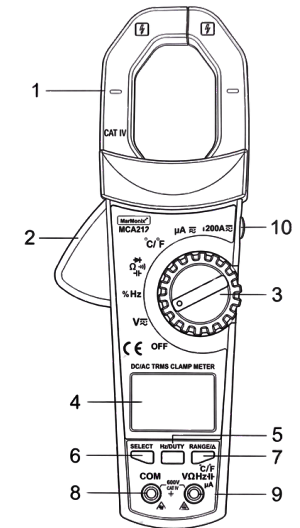

D. Instruction

(1) Measure AC/DC Voltage

1. Connect the black lead to the COM terminal and the red lead to the VΩHz terminal.
2. Set the rotary switch to AC/DC Voltage mode.
3. Press SELECT to switch between AC and DC.
4. Apply probes to the correct circuit test points to measure voltage.
5. Read the measured value on the display.

Caution:

- Do not measure voltage exceeding the specified MAX value.
- Do not touch the circuit while measuring high voltage.

(2) Measure AC/DC Current (A)

1. Set the rotary switch to AC/DC Current (A) mode.
2. Press SELECT to toggle between AC and DC.
3. Press Jaw Release and position the conductor at the center of the clamp jaws (see illustration).
4. Read the measured current on the display.

Caution:

- Do not measure current exceeding the specified MAX value.
- Measure a single conductor only, as opposing currents will cancel.

(3) Measure AC/DC Current (μ A)

1. Connect the black lead to COM and the red lead to V Ω Hz ($\leq 6000 \mu$ A).
2. Set the rotary switch to AC/DC Current (μ A).
3. Press SELECT to toggle between AC and DC.
4. Open the circuit to be tested, connect leads across the break, and apply power.
5. Read the measured current on the display.

Caution:

- Do not measure current beyond the specified MAX value.
- For unknown current, use the 20A terminal and Current-A mode first, then switch to mA/ μ A terminal and lower range if required.

Do not input voltage exceeds 36V DC or 25V AC when you are at the setting of measuring current.

(4) Measure Resistance

1. Connect the black lead to the COM terminal and the red lead to the V Ω Hz terminal.
2. Set the rotary switch to Resistance mode; the display will show "OL."
3. Apply probes to the circuit test points to measure resistance.

4. Read the measured resistance on the display.

Caution:

- Disconnect circuit power and discharge capacitors before testing resistance.
- Do not apply voltage in Resistance mode.

(5) Measure Continuity

1. Connect the black lead to the COM terminal and the red lead to the V Ω Hz terminal.
2. Set the rotary switch to Resistance mode and press SELECT once to enter Continuity mode.
3. Apply probes to the circuit test points.
4. The beeper sounds when resistance is below 50 Ω , indicating a short circuit.

Caution: Do not apply voltage in Continuity mode.

(6) Measure Diode

1. Connect the black lead to the COM terminal and the red lead to the V Ω Hz terminal.
2. Set the rotary switch to Resistance mode and press SELECT twice to enter Diode mode.
3. Place the red probe on the anode and the black probe on the cathode of the diode.
4. Read the forward bias voltage on the display.
5. If polarity is reversed or the diode is faulty, the display shows "OL."

Caution:

- Do not apply voltage in Diode mode.
- Disconnect circuit power and discharge capacitors before testing diodes.

(7) Measure Capacitance

1. Connect the black lead to the COM terminal and the red lead to the V Ω Hz terminal.
2. Set the rotary switch to Resistance mode and press SELECT three times to enter Capacitance mode.
3. Place the red probe on the anode and the black probe on the cathode of the capacitor.



4. Read the capacitance value on the display once stabilized.

Caution: Disconnect circuit power and fully discharge capacitors before testing capacitance.

(8) Measure Frequency and Duty Cycle

1. Connect the black lead to the COM terminal and the red lead to the VΩHz terminal.

2. Set the rotary switch to AC Voltage, AC Current (A), or AC Current (μA) mode; press the Hz/Duty Cycle button once for Frequency mode or twice for Duty Cycle mode.

3. Apply probes to the desired circuit points.

4. Read the measured frequency or duty cycle on the display.

Caution: The Hz/Duty Cycle button is only for low-frequency measurements at high voltage.

(9) Measure Frequency

1. Connect the black lead to the COM terminal and the red lead to the VΩHz terminal.

2. Set the rotary switch to Frequency mode.

3. Apply probes to the desired circuit points.

4. Read the frequency value on the display.

Caution: Frequency mode is only for high-frequency measurements at low voltage.

(10) Measure Temperature

1. Connect the black thermocouple probe to the COM terminal and the red probe to the VΩHz terminal.

2. Set the rotary switch to Temperature mode; the display shows ambient temperature. Press SELECT to toggle °C/°F.

3. Apply probes to the desired test points.

4. Read the measured temperature on the display.

Caution: Do not apply voltage in Temperature mode.

(11) Auto Power Off

1. The device powers off automatically after 15 minutes of inactivity.

2. The built-in beeper sounds five times one minute before shutdown.

3. Press SELECT to restart the device.

4. To disable Auto Power Off, hold SELECT while powering on; five beeps confirm successful deactivation.

General Maintenance

Except for battery and fuse replacement, do not attempt repairs or service unless qualified and equipped with the appropriate calibration, performance test, and service instructions.

- Do not operate near heat, moisture, flammable, explosive, or strong magnetic environments.
- Clean with a damp cloth and mild detergent; avoid abrasives or solvents.
- Remove all input signals before cleaning.
- Remove batteries if the device will be unused for extended periods to prevent leakage.
- When "  " appears on the display, replace batteries as follows: loosen the screw, remove the cover, install new batteries of the same type, replace the cover, and fasten the screw.
- Replace fuses using the same procedure; use only fuses of the original type.

Warning:

1. Do NOT exceed the "maximum value" indicated in the Specification;
2. Do NOT input voltage at the Current Mode, the Resistance Mode, the Diode Mode, the Continuity Mode, or the Temperature Mode;
3. Do NOT use the product when the batteries or the battery cover is not placed properly;
4. Turn off the product and remove the test leads from the test points before changing batteries or fuses.

Troubleshooting

If your product does not function as normally, the following steps may help. If the problem still can not be solved, please contact your dealer.

Problem	Possible Reason
Display Mulfuction	Low battery; replace batteries
 Symbol	Replace batteries
No current input	Replace fuse