

MIT 700 Infrared Thermometer

User Manual



Part Number: 7603121
GTIN: 6298043998185

1

A. Introduction

This infrared thermometer measures surface temperature safely and quickly, making it suitable for hot, hazardous, or hard-to-reach objects without contact.

The unit consists of precision optics, a temperature sensor, a signal amplifier, a processing circuit, and an LCD display. The optics collect infrared energy emitted by the target and focus it onto the sensor, which converts it into an electrical signal. After amplification and processing, the signal is digitized and shown on the LCD.

B. Warnings & Cautions

1. Warnings

To prevent injury or damage, observe the following:

- Do not point the laser directly at eyes or at reflective surfaces.
- The instrument cannot measure through transparent materials such as glass or plastic; it will display the surface temperature of those materials instead.
- Steam, dust, smoke, or other airborne particles may obstruct the optics and reduce measurement accuracy.

2. Cautions

The infrared thermometer must be protected against the following:

- Strong electromagnetic fields from arc welders or induction heaters.
- Avoid thermal shock from sudden ambient temperature changes; allow 30 minutes for the unit to stabilize before use.
- Avoid prolonged exposure to, or placement near, high-temperature objects.

C. Distance to Spot size

1. D to S Ratio: When measuring, note the Distance-to-Spot (D:S) ratio—As the distance increases, the spot size becomes larger.

This unit offers a 12:1 D:S ratio with an integrated laser for precise targeting.

2

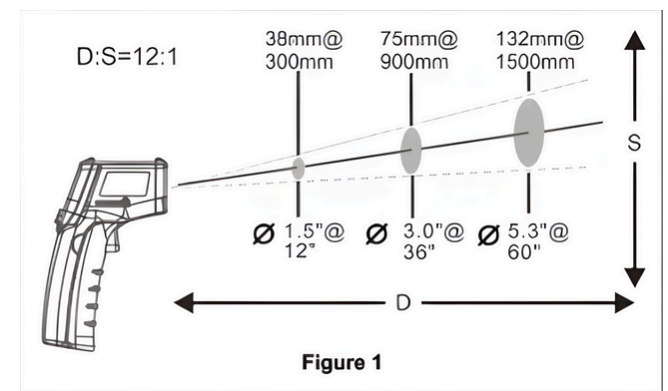

Figure 1

2. Field of View: Ensure that the target area is larger than the instrument's spot size. For smaller targets, reduce the measuring distance to maintain accuracy. When precise measurement is required, the target area should be at least twice the diameter of the spot.

D. Emissivity

Most organic, painted, or oxidized surfaces have an emissivity of 0.95, preset in the unit for accurate measurement. Shiny metals may give errors; adjust the emissivity or cover with tape/black paint and measure once it has reached the temperature of the material.

Material	Emissivity	Material	Emissivity
Aluminum	0.30	Iron	0.70
Asbestos	0.95	Lead	0.50
Asphalt	0.95	Limestone	0.98
Basalt	0.70	Oil	0.94
Brass	0.50	Paint	0.93
Brick	0.90	Paper	0.95
Carbon	0.85	Plastic	0.95
Ceramic	0.95	Rubber	0.95
Concrete	0.95	Sand	0.90
Copper	0.95	Skin	0.98
Dirt	0.94	Snow	0.90
Frozen food	0.90	Steel	0.80
Hot food	0.93	Textiles	0.94
Glass(plate)	0.85	Water	0.93
Ice	0.98	Wood	0.94

3

E. Operation

1. Operating the unit:

1. Open the battery compartment and insert two 1.5 V AAA batteries. Ensure correct polarity.
2. Pull the trigger to power on.
3. Aim at the target surface and press the trigger; the temperature will appear on the LCD. The laser pointer is for aiming only and does not affect the temperature reading.

2. Locating a Hot Spot

To locate a hot spot, start by aiming outside the target area, then slowly scan across the surface until the highest temperature point is found.

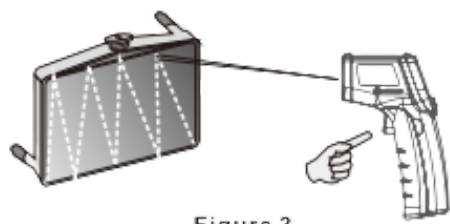
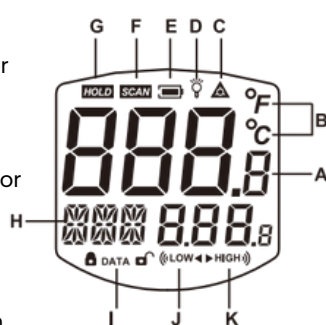

Figure 3

F. LCD Display & Buttons

1. LCD Display

- A) Temperature Reading
- B) Measurement Unit
- C) Laser Status Indicator
- D) Backlight Status Indicator
- E) Battery Level Indicator
- F) Scan Status Indicator
- G) Hold Indicator
- H) Mode / Emissivity Indicator
- I) Data Storage / Recall Indicator
- J) Low-Temperature Alarm Indicator
- K) High-Temperature Alarm Indicator



4

2. Diagram description: (figure 2).

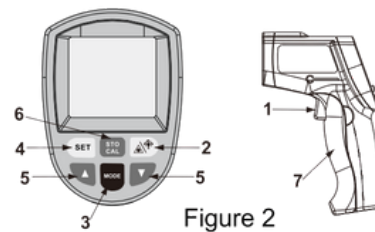

Figure 2

- 1. Trigger:** On power-up, the LCD shows software version (VERXX) for 1 second, then enters measurement mode with SCAN icon. Release to display the reading with HOLD icon. Built-in auto power-off after ~10 seconds of inactivity.
- 2. Laser / Backlight Switch:** Toggles laser pointer and LCD backlight.
- 3. Key Functions:** Press Key 3 to cycle sub-display through MAX → MIN → DIF → AVG → HAL → LAL → STO → EMS. Press Key 4 to enter the selected mode.
 - a) MAX – Maximum temperature
 - b) MIN – Minimum temperature
 - c) DIF – Difference from the reading prior to entry
 - d) AVG – Average temperature
 - e) HAL – High-temperature alarm; set trigger with Key 5, confirm with Key 4. Displays 'Hi' and sounds alarm when limit is exceeded.
 - f) LAL – Low-temperature alarm; set trigger with Key 5, confirm with Key 4. Exceeding trigger displays LOW with audible alarm.
 - g) STO – Data storage; indicators show lock & DATA. Press Key 4, then Key 6 to store. Up to 30 memory slots available. Recall data in normal mode with Key 6. Hold Key 6 for 3 seconds to clear all data.
 - h) EMS – Emissivity adjustment; press Key 5 to set value, confirm with Key 4.
- 4. SET Button:** Confirms selections and enters adjustment settings for HAL, LAL, EMS.
- 5. Arrow Keys (▲ / ▼):** Adjust values in HAL, LAL, and EMS; navigate stored data
- 6. STO / CAL Button:** Short press: Save current reading (up to 30 records). Long press (3 seconds): Clear all stored data.
- 7. Celsius/Fahrenheit Switch:** Located in the battery compartment; use slide switch for unit conversion.

5

G. Maintenance

1. Lens Cleaning

Blow off loose particles with clean compressed air. Remove any remaining debris with a soft cotton swab slightly moistened with water.

2. Case Cleaning

Wipe the case with a damp sponge or cloth and mild soap.

Notes

1. Do not use solvents on the plastic lens.
2. Do not immerse the unit in water.

H. Specification

Temperature range	-50°C~750°C (-58°F~1382°F)
Accuracy	0°C~750°C(32°F~1382°F): ±1.5°C(±2.7°F) or ±1.5% -50°C~0°C(-58°F~32°F): ±3°C (±5°F) Whichever is greater
Resolution	0.1°C or 0.1°F
Repeatability	1% of reading or 1°C
Response time	500 mSec, 95% response
Spectral response	8um~14 um
Emissivity	0.10~1.00 Adjustable (0.95 Preset)
Distance to Spot size	12:1
Operating Temperature	0°C ~40°C (32°F ~ 104°F)
Operating Humidity	10%RH~95%RH non-condensing, up to 30°C(86°F)
Storage Temperature	-20°C ~ 60°C (-4°F~140°F)
Power	9V Alkaline or NiCd battery
Typical battery life (Alkaline)	Non-laser mode: 22 hrs; Laser Models: 12 hrs
Weight	222g
Dimension	111*50*172mm

Disclaimer

The manufacturer assumes no responsibility for any consequences resulting from the use or misuse of this product. Product specifications and manual content are subject to change without prior notice.

6