



# MVB 200

Pen-Type Vibration Meter

Instruction Manual



#### Disclaimer

The manufacturer assumes no responsibility for any consequences resulting from the use or misuse of this product. Product specifications and manual content are subject to change without prior notice.

**Part Number:** 7603181  
**GTIN:** 6298043998253



**Part Number:** 7603181  
**GTIN:** 6298043998253

# Table of contents

## Introduction

Introduction.....	(01)
Features.....	(01)
Specifications.....	(02)
Diagram of the product.....	(03)
LCD displays.....	(04)

## Operation

Selection probe tip.....	(05)
Battery Installation.....	(06)
Turn on the unit and check-up battery.....	(07)
Select measurement mode.....	(08)
Select high/low frequency.....	(09)
Measurement.....	(10)
Vibration conversion chart.....	(12)
Contact resonance in acceleration measurement.....	(13)

## Other items

Attention.....	(15)
Warranty.....	(15)
Maintenance.....	(16)



MarMonix.co



info@MarMonix.co

**MarMonix**<sup>®</sup>  
MVB 200

## Introduction

Marmonix MVB 200 employs the piezoelectric effect of polarized ceramic as its core design principle, ensuring precise vibration detection. It is intended for monitoring diverse vibrating mechanical equipment, with particular focus on rotating and reciprocating machinery. The unit is capable of measuring acceleration, velocity, and displacement, making it broadly applicable in mechanical manufacturing, electric power, metallurgy, and general industrial use.

## Features

- **Compact and portable design:** Simple to operate with a lightweight, durable structure, making it ideal for field and on-site measurements.
- **Visual display:** LCD screen presents both measurement values and operating status for clear, real-time monitoring.
- **Multi-parameter capability:** Measures acceleration, velocity, and displacement to cover the full spectrum of vibration analysis needs.
- **Frequency selection:** Adjustable vibration frequency modes enhance measurement flexibility across different machines and conditions.
- **High-sensitivity probe:** Ensures precise detection of vibration signals. Supplied with both long and short probe heads to suit varying measurement environments.
- **AC signal output:** Provides an external interface for advanced analysis or connection to additional monitoring equipment.
- **Low power indication:** Alerts the user to replace or recharge the battery, preventing unexpected shutdowns.
- **Automatic power-off:** Conserves energy by switching the instrument off after periods of inactivity.
- **LCD backlight:** Enhances visibility of readings in low-light or industrial environments.

## Specifications

Technical Parameter	Technical Specification
Vibration Pickup	Piezoelectric ceramic accelerometer (shear-type)
Acceleration Range	0.1 ~ 199.9 m/s <sup>2</sup> peak
Velocity Range	0.1 ~ 199.9 mm/s rms
Displacement Range	0.001 ~ 1.999 mm p-p
Range Limitation	Velocity and displacement range limited by 199.9 m/s <sup>2</sup> acceleration
Measurement Accuracy	±5% ±2 digits
Acceleration Frequency Range	10 Hz ~ 1 kHz (LO), 1 kHz ~ 15 kHz (HI)
Velocity Frequency Range	10 Hz ~ 1 kHz (LO)
Displacement Frequency Range	10 Hz ~ 1 kHz (LO)
Display Update Cycle	1 second
LCD Display	3½-digit display
Single Output	AC output 2 V peak (full scale)
Load Impedance	≥10 kΩ (earphones supported)
Power Supply	9V Alkaline battery
Static Current	≤20 μA
Operating Current	≤25 mA
Battery Life	20 hours continuous use
Auto Power-Off	Automatically turns off in 60 seconds
LCD Backlight	7 seconds
Operating Temperature	0 ~ 40 °C
Operating Humidity	30 ~ 90% RH
Low Battery Indication	6.9V ±0.2V
Dimensions	67 × 30 × 183 mm
Weight	182 g (including battery)



## Diagram of the product

### (1) A Schematic Diagram

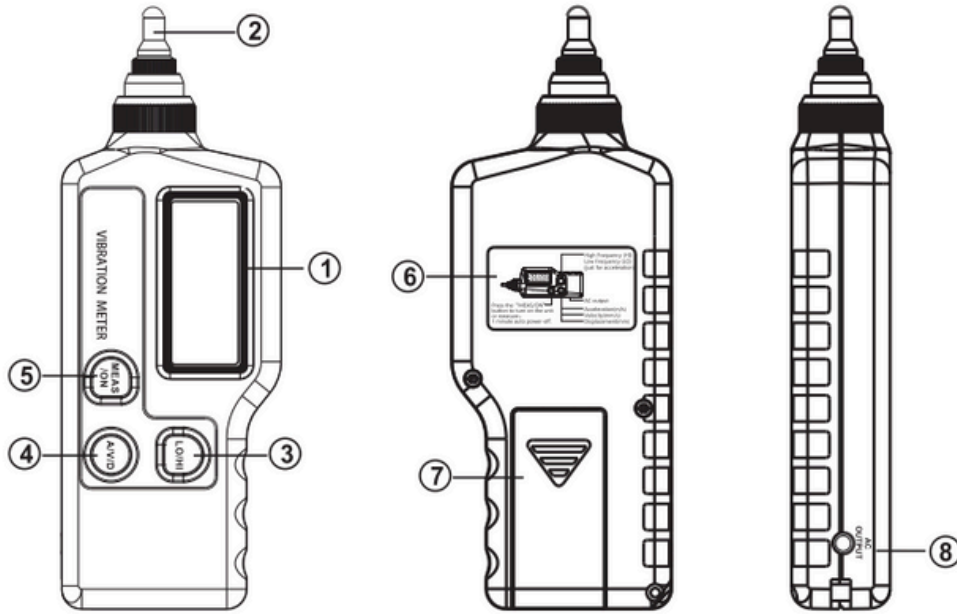

1. **LCD Screen:** Displays measurement values, operating status, and function indicators.
2. **Probe:** High-sensitivity sensor for vibration detection.
3. **LO/HI Frequency Selection Key:** Available only in acceleration mode; selects low or high frequency range.
4. **A/VD Measurement Mode Key (Acceleration / Velocity / Displacement):** Switches between measurement parameters.
5. **MEAS/ON Key:** Power and measurement key; Press once to power on. Hold during measurement, and release to freeze the displayed value.
6. **Quick Instruction Label:** Provides a concise reference for basic operation.
7. **Battery Door:** Access cover for battery replacement.
8. **AC Signal Output Jack:** Interface for transmitting measurement signals to external devices.

### (2) Description of the symbols on the display unit

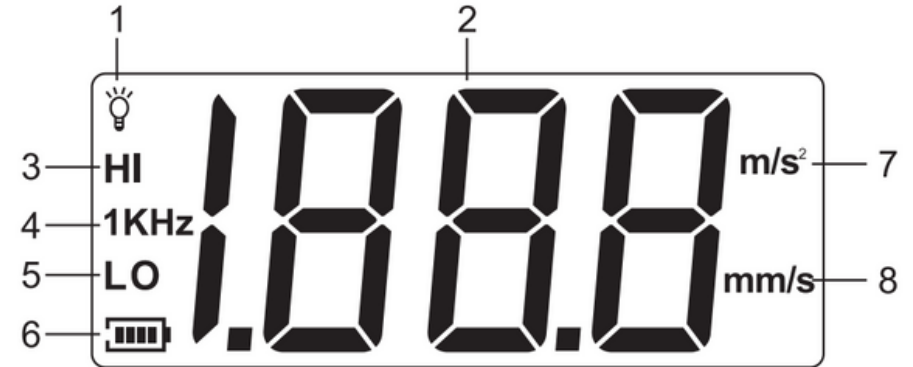

1. **Backlight Indicator:** The LCD backlight automatically activates for 7 seconds after any button press, improving visibility in low-light or industrial environments.
2. **Measurement Data:** The main numeric display shows real-time vibration readings according to the selected measurement mode.
3. **HI:** Indicates the instrument is operating in high-frequency mode for acceleration measurement, suitable for detecting higher vibration signals.
4. **1 kHz:** Confirms the selected vibration frequency is 1 kHz.
5. **LO:** Indicates the instrument is operating in low-frequency mode, allowing accurate detection of lower vibration ranges.
6. **Battery Status Icon:** Provides a five-level indication of battery condition:
  - Sufficient power
  - Moderate power available
  - Nearly low
  - Critically low, replacement required soon
  - Fully depleted, instrument inoperable until replaced
 This prevents unexpected shutdowns during measurement.
7. **m/s<sup>2</sup> Unit Display:** Appears when the instrument is set to acceleration mode, ensuring correct interpretation of values.
8. **mm/s and mm Unit Displays:** "mm/s" is shown in velocity mode, while "mm" is shown in displacement mode, allowing the operator to immediately confirm the measurement parameter in use.

## Select Probe tip

The instrument supports three probe configurations. Selecting the correct setup is essential for obtaining accurate, stable, and reliable vibration measurements in different working environments.

### (1) Short Probe Tip (S)

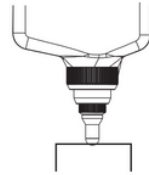

- **Default installation:** Pre-mounted at the factory.
- **Application:** General-purpose vibration measurements across a wide range of machinery.
- **Advantage:** Provides balanced sensitivity and stability, ensuring accurate response values for most standard surfaces.

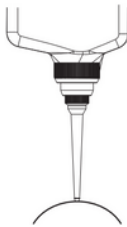

### (2) Long Probe Tip (L)

- **Supplied accessory:** Included inside the carrying case.
- **Application:** Ideal for measurements in restricted or narrow spaces, or on special-shaped components where the short probe cannot reach.
- **Advantage:** Extended length allows access to difficult points while maintaining quick response.

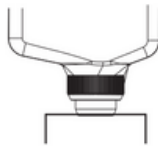

### (3) Without Probe Tip

- **Configuration:** Probe used directly without an attached tip.
- **Application:** Optimized for smooth, flat surfaces where stable contact is possible.
- **Advantage:** Eliminates probe-tip influence, resulting in highly stable readings.

## Battery Installation

### (1) Opening the Battery Compartment

Hold the main unit firmly with your left hand to keep it stable. Using the thumb of your right hand, press down on the battery door and slide it in the direction indicated by the arrow. This releases the lock and allows the door to open safely, as shown in the figure.

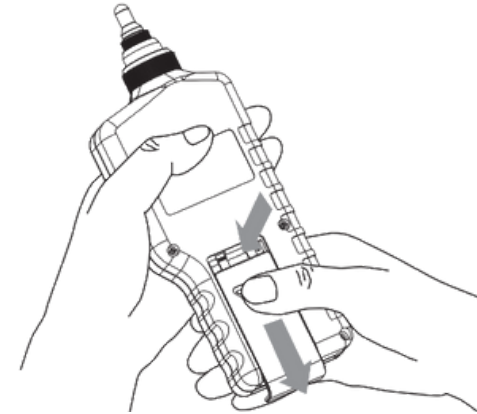

### (2) Inserting Battery

Insert a 9V battery into the battery compartment, ensuring correct polarity, and close the battery door securely as shown in the figure.

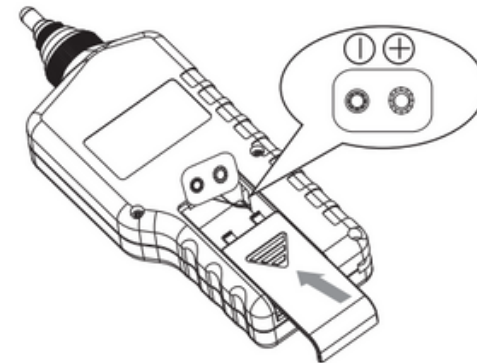

## Turning On the Unit and Battery Check

### (1) Powering On

Press the ON key to switch on the instrument, as shown in the figure.



### (2) Startup Display and Battery Status

When powered on, the entire LCD screen illuminates for approximately one second as part of the self-test sequence. The unit then defaults to acceleration measurement mode.



Low battery indication

If, during startup, the battery icon appears or remains visible on the LCD, it indicates insufficient battery power. In this case, promptly replace the 9V battery to ensure stable operation and accurate measurement, as shown in the figure.

## Selecting Measurement Mode

### (1) Acceleration Mode (Default)

Press the **A/VID** key to select the measurement mode. By default, the unit starts in acceleration mode, as shown in the figure.



### (2) Velocity Mode

Press the **A/VID** key again to switch to velocity measurement mode, as shown in the figure:



### (3) Displacement Mode

Press the **A/VID** key once more to enter displacement measurement mode, as shown in the figure.



## Select High/Low Frequency

### (1) toggle between High Frequency & Low Frequency

Press the **LO/HI** key to toggle between High Frequency (HI) and Low Frequency (LO) modes, as shown in the figure.

- HI Mode: Used for detecting higher vibration signals and rapid changes.
- LO Mode: Used for monitoring lower vibration ranges with greater stability.

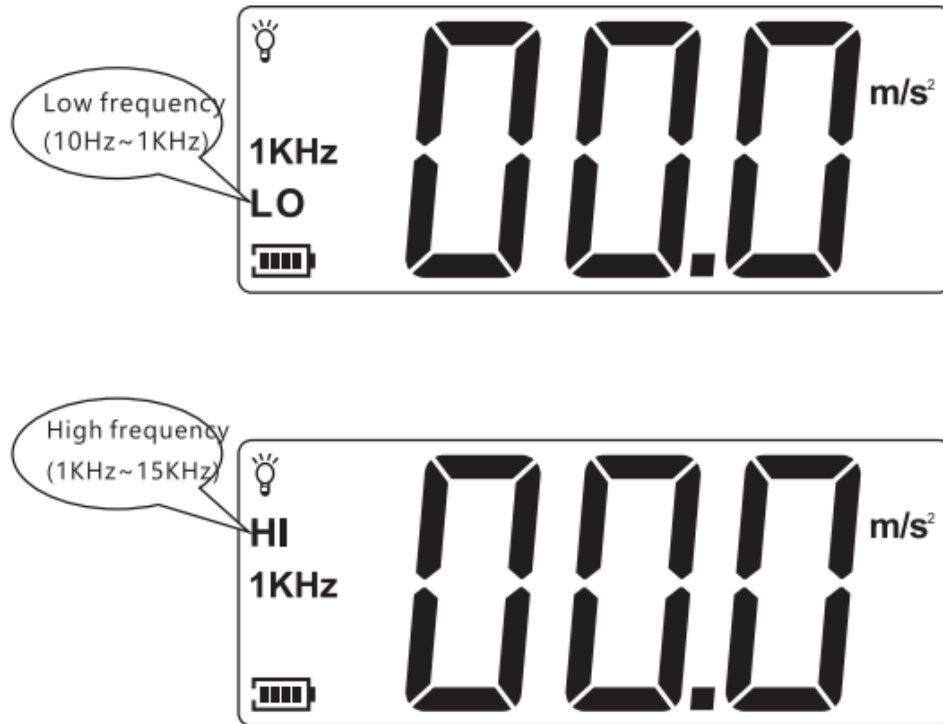

#### Note:

High/Low frequency selection is functional only in acceleration measurement mode. It is not applicable in velocity or displacement modes.

### (2) Measurement

- Select the appropriate measurement mode (Acceleration, Velocity, or Displacement) and frequency setting (HI or LO) according to the vibration characteristics of the structure under test.
- Hold the instrument firmly and keep the **MEAS/on** key depressed with your right thumb. Press the probe firmly against the test surface using a consistent force of 500 g to 1 kg. The measured result will appear on the LCD screen.
- When the MEAS key is released, the displayed value is automatically held on the screen for review, as shown in the figure.

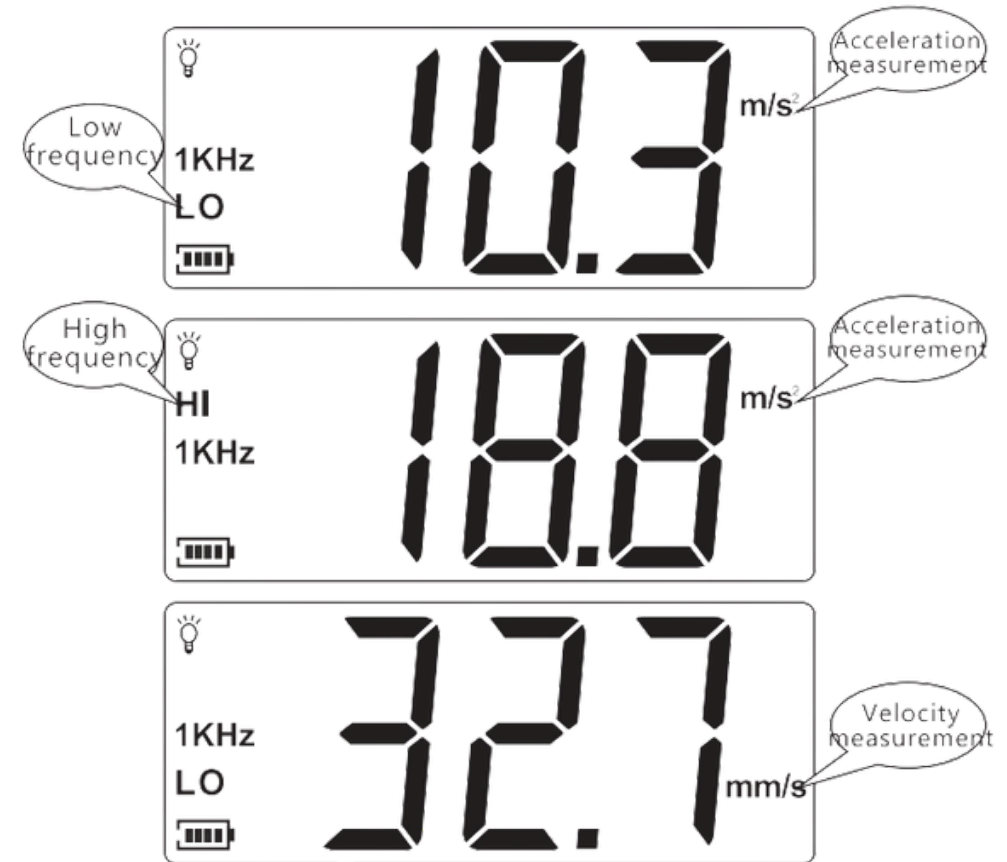



When the MEAS key is pressed again, the previous value is cleared and a new measurement can be performed.

### Important Notes

- **Short Probe (S)**

The short probe is versatile and supports vibration measurement across both High (HI) and Low (LO) frequency ranges. Its design ensures accurate response at higher frequencies, making it suitable for general-purpose vibration testing.

- **Long Probe (L)**

The long probe is designed for accessibility in narrow or hard-to-reach areas but is limited to Low (LO) frequency measurements. At higher frequencies (above 1 kHz), or during acceleration measurement, the longer probe may introduce mechanical resonance at higher frequencies, affecting accuracy. In such cases, replace it with the short probe for accuracy.

- **Automatic Frequency Adjustment**

When switching from Acceleration mode (HI frequency) to either Velocity or Displacement mode, the system automatically resets to Low (LO) frequency. This safeguard prevents false readings, as higher frequency response is not compatible with velocity and displacement measurement functions.

- **Auto Power-Off**

If the instrument is not used for 60 seconds, it powers down automatically. This feature conserves battery life and protects against unnecessary energy drain.

- **Auto Backlight-Off**

The LCD backlight switches off after 7 seconds of inactivity. This conserves power while still ensuring readability in dim environments when needed.

### Vibration conversion chart

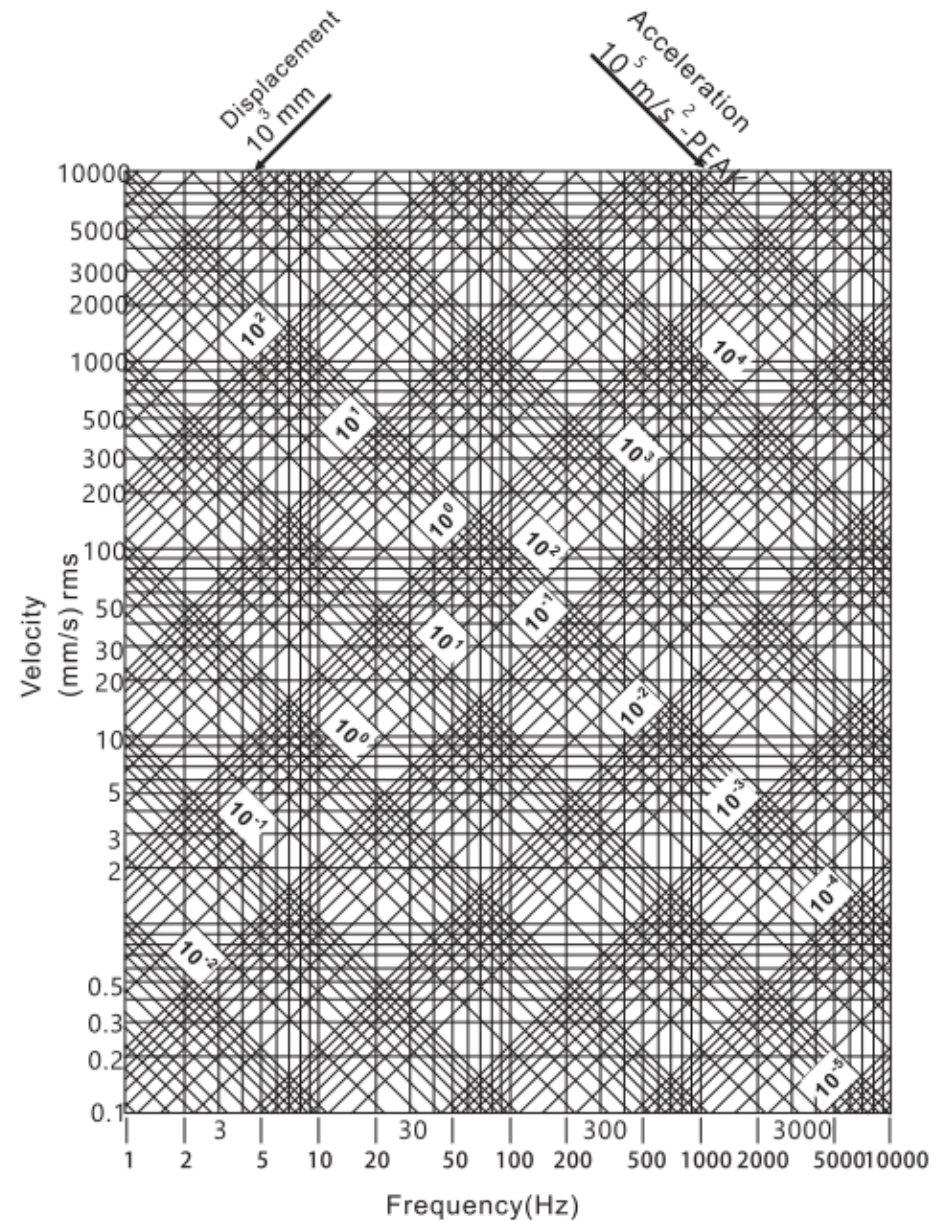

Contact resonance in acceleration measurement  
(Measured using an FFT signal analyzer)

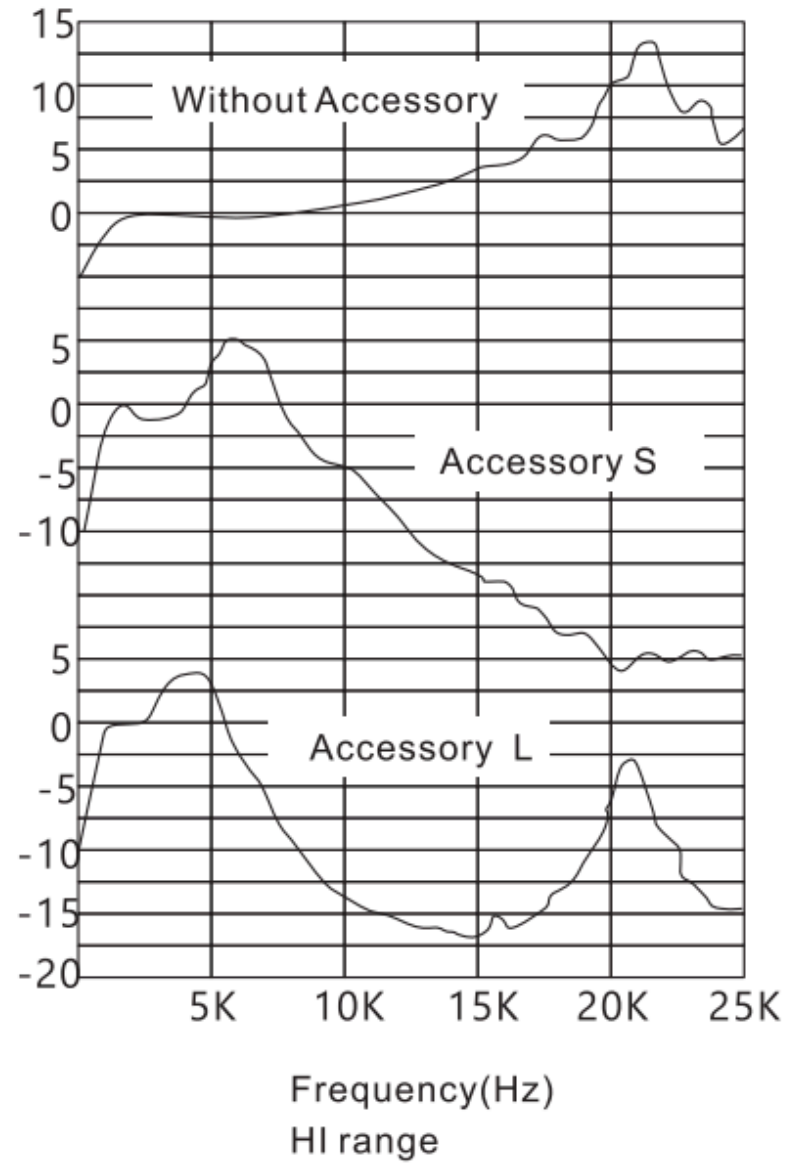
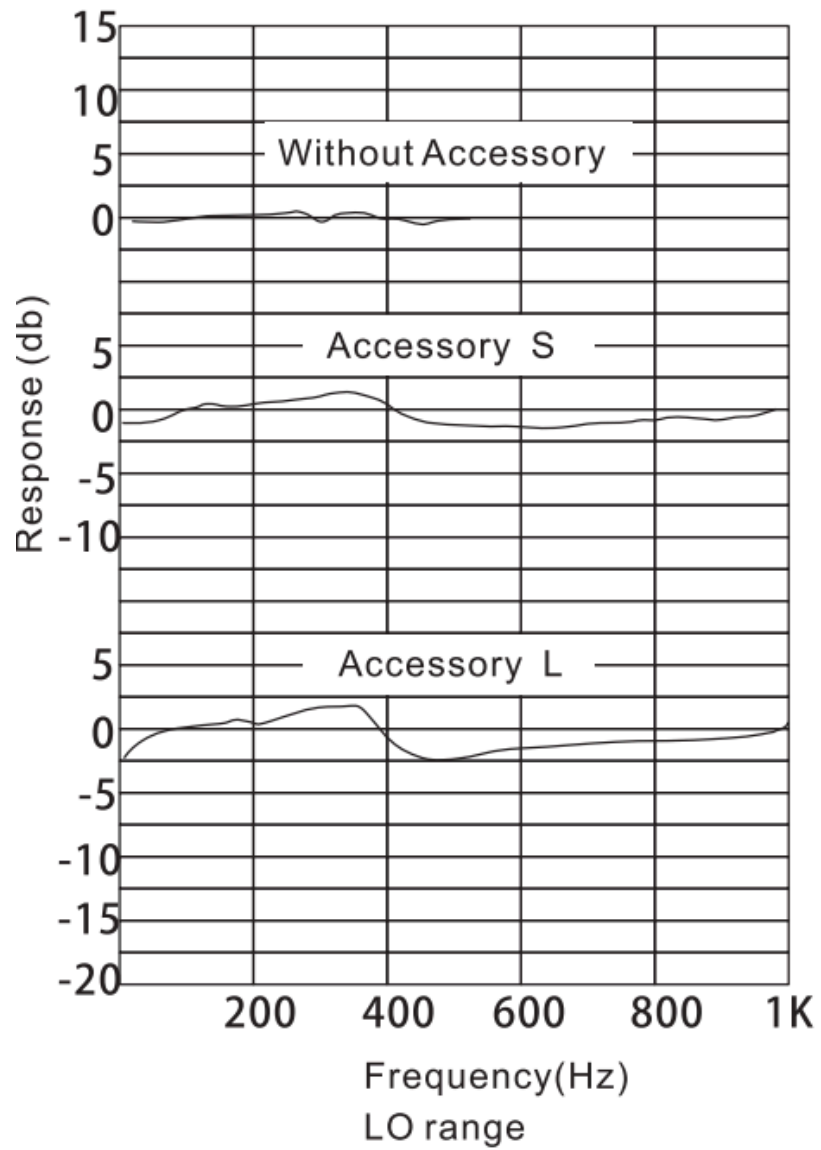

## Attention, Maintenance & Warranty

### (1) Attention

#### Warning

When measuring exposed rotating parts or power transmission components, exercise extreme caution. Improper handling may result in the probe, cables, or operator becoming entangled in the machinery, leading to serious accidents.

#### Caution

Excessive vibration of the unit may cause the output port to generate extremely high sound pressure through the signal output plug. This can be harmful to the human ear. Always handle the output connection carefully and avoid placing it near the ear during operation.

### (2) Warranty

- Please refer to the warranty card for detailed warranty terms and conditions.
- The manufacturer accepts no liability for:
  - 1.Damages occurring during transportation by the customer
  - 2.Improper use or operation
  - 3.Unauthorized manipulation, alterations, or repair attempts
  - 4.Claims made without a valid warranty card or purchase invoice

### (3) Maintenance

#### 1. Battery Replacement and Care

- Low Battery Indication: If the battery icon appears on the LCD after powering on, the unit does not have sufficient power for accurate operation. Replace the 9V battery immediately. Refer to page 9 of this manual for the illustrated replacement procedure.
- Extended Storage: Always remove the battery if the unit will remain unused for long periods. This prevents leakage, which can corrode the battery compartment, damage internal circuitry, and compromise safety.

#### 2. Storage and Operating Conditions

To maintain accuracy and extend service life, avoid storing or operating the instrument under the following conditions:

- Moisture and Dust: Exposure to water splashes, condensation, or heavy dust may damage electronic components.
- Corrosive Atmospheres: Air containing high salt (marine environments), sulfur (industrial exhaust), or other corrosive gases accelerates deterioration of internal parts.
- Chemical Vapors: Operation near solvents, fuels, or industrial fumes may degrade sensor performance.
- Extreme Temperature/Humidity: Avoid environments exceeding 50 °C or 90% relative humidity, as well as direct sunlight, which can damage the LCD and shorten battery life.

#### 3. Prohibited Actions

Do not disassemble the unit, attempt internal modifications, or carry out unauthorized repairs. Such actions may void the warranty and compromise measurement accuracy.

#### 4. Cleaning and Care

- Do not use alcohol, thinners, or chemical solvents to clean the housing, as these will damage the LCD surface and degrade protective coatings.
- For safe cleaning, lightly wipe the exterior with a soft cloth dampened with clean water. Avoid excessive moisture, especially near the probe or connectors.

